

A Hybrid Method for Mitigation Strategy on Palm Oil Supply Chain: A Case Study in Indonesia

Nur Afni A Kutanga¹, Annisa Kesy Garside^{2*} & Dana Marsetiya Utama³

Received 14 August 2022; Revised 29 October 2022; Accepted 4 December 2022;
© Iran University of Science and Technology 2023

ABSTRACT

Palm oil is a commodity whose demand continues to increase, requiring proper risk management in the supply chain. This study aims to develop a hybrid method that integrates probability impact matrix, analytical network process, and house of risk to mitigate strategies in the palm oil supply chain. The Probability Impact Matrix (PIM) method is used to map the priority risk agents and determine the occurrence value of the risk agents, and Analytical Network Process (ANP) is used to determine the severity value of the risk event. Furthermore, the House of Risk (HOR) is proposed to determine the priority of the mitigation strategy. The proposed method was applied in a case study on the palm oil supply chain in Indonesia. The research results show that ten priority risk agents and 6 mitigation strategies were obtained based on the proposed method to overcome risk agents in palm oil supply chain.

KEYWORDS: *Palm oil; House of risk; Mitigation strategy; Risk; Supply chain.*

1. Introduction

In the food and cosmetic industries, there has been an increase in global demand for palm oil as a low-cost oil or fat supply. In 2018, 19.72 million tonnes of such vegetable oil were consumed globally [2]. Palm oil production, an important economic activity for Colombia's development, has helped it become the region's top producer [25]. More than 400,000 hectares of African oil palm were planted in 2017 to meet domestic and international demand in the food, pharmaceutical, and energy industries [27], [19]. The palm oil industry in South East Asia is expanding rapidly, particularly in Indonesia. Palm oil has become the region's most important commodity in recent decades [9]. Despite its expansion, Indonesia's palm oil industry is

constantly working to improve its competitiveness in the global oil market.

Crude palm oil (CPO) is extracted from fresh oil palm fruit bunches and is a source of high-value antioxidants such as tocotrienols and beta-carotene. CPO is a distinct bright orange oil that can be used in both domestic cooking and biodiesel production [12]. Delays in production and delivery can harm a CPO manufacturer's reputation, as well as its sales and financial performance [31]. Furthermore, a thorough understanding of supply chain risk mitigation and response opens up new research avenues [14]. Focusing on supply chain management is one way to stay competitive in the supply chain ecosystem [11], [17], [34].

Supply chain risk management is a concept to control and coordinate the risks that can be generated and mitigation actions in the company's supply chain [32]. Supply Chain Risk Management (SCRM) is a combination of the supply chain management concept with risk management [10]. Because SCRM involves reciprocity in a typical supply chain network, all members in the network will be potentially exposed to risk [16].

In recent years, researchers have published a number of supply chain risk mitigation. [32],

* Corresponding author: *Annisa Kesy Garside*
annisa@umm.ac.id

1. *Departemen of Industrial Engineering, Faculty of Engineering, University of Muhammadiyah Malang, Malang, Indonesia.*
2. *Departemen of Industrial Engineering, Faculty of Engineering, University of Muhammadiyah Malang, Malang, Indonesia.*
3. *Departemen of Industrial Engineering, Faculty of Engineering, University of Muhammadiyah Malang, Malang, Indonesia.*

[20], and Umami et al. have used the house of risk to determine priority risks and the Analytical Network Process (ANP) to select priority mitigation strategies. Integration of Failure Modes and Effects Analysis (FMEA) and ANP also proposed to determine priority risk [3], [35] used the House of Risk to mitigate risks in the high way road construction. House of Risk have also applied to mitigation in supply chain activities such as material procurement [7], production process [22], [24], distribution [6] [18]. Some procedure have also offered on palm oil supply chain mitigation strategies by researchers. [4] proposed modified failure mode and effect analysis, and House of Risk was offered by [28], and Probability Impact Matrix (PIM) [13]. Integrating risk assessment, performance measurement and supply chain optimisation, which involve a decision-making tool also was developed by [8].

Based on previous research, research on palm oil supply chain mitigation strategies are rarely investigated. To the best of our knowledge only four papers discussed this problem [4], [28], [8], [13]. House of Risk (HOR) is a supply chain mitigation risk method that popular to manage supply chain risk [21]. Unfortunately, this procedure has lacks such as risk events that do not have a relationship between one risk event and another, and the risk agent is not assessed at the initial risk level, thus causing risk agents who are not at risk to be involved in the risk assessment. Hence, this research attempts developed a hybrid method to mitigate strategies palm oil supply chain. This research aims to propose a hybrid method to mitigate strategies palm oil supply chain based on Probability Impact Matrix (PIM), ANP, and HOR. It has never been applied previous research on supply chain mitigation strategies. In proposed method, PIM is used to determine the value of the risk score and risk zone of each risk agent. Only risk agents that are in the yellow and red zones will be further processed in HOR. ANP is used to determine the relationship between risk events and the severity value of risk events, and HOR is used to determine the priority of risk agents and mitigation strategies. The proposed procedure is applied to a supply chain case study in a company in Indonesia. The research contributions are described as follows: (1) propose a new hybrid procedure based on the integration of PIM, ANP and HOR; and (2) provide recommendations for supply chain mitigation in a case study of the palm oil supply chain in Indonesia.

2. Methods

2.1. Proposed framework

This section discusses the proposed framework to mitigate supply chain which consists of five stages. A hybrid method is proposed which involve probability impact matrix (PIM), analytical network process (ANP) and house of risk (HOR) methods. The proposed framework can be seen in Figure 1. The first stage is to identify supply chain activities based on the Supply Chain Operations Reference (SCOR), followed by the identification of risk events and risk agents that occur during the supply chain process. The SCOR model has 5 processes, namely, 'plan, source, make, deliver and return [23].

The second stage is the mapping of risk agents using a PIM, which is used to determine the risk zone for each risk agent. The 5 x 5 matrix is developed with impacts ranging from scale 1, being very low, to 5, very high, on the horizontal axis and probabilities on the vertical axis. The five zones in PIM are (1) Dark red zone, the risk in this zone is very important and must be handled immediately; (2) Light red zone, the risk in this zone is very important and must be avoided, reduced or diverted; (3) Yellow zone, the risk in this zone is quite important and must be handled; (4) Dark green zone, the risk in this zone is low, the risk in this zone is sufficiently monitored; (5) Light green zone, the risk in this zone has the lowest impact, the risk is sufficiently monitored [13]. Risk agents in the yellow and red zones is processed in phase 1 of house of risk. It is used so that risk agents categorized as yellow and red become a concern in risk mitigation.

The third stage is to determine the severity value of the risk event using the ANP. ANP is a procedure that weights indicators based on the interrelationship of indicators and was proposed by Saaty and Vargas (2013). The first stage of severity assessment using ANP is determining the interrelationship risk event, which is then assessed on the level of importance based on a pairwise comparison matrix. In the pairwise comparison on risk event, ANP uses 9-scale importance level where 1 denotes equal importance and 9 means that the first risk event is extremely more important than the second risk event. The next step is to determine the eigenvector value, and unweighted supermatrix is created by entering all the calculated eigenvectors into a supermatrix. Weighted supermatrix is created by multiplying each content of the unweighted supermatrix with the criteria comparison matrix (cluster matrix). Furthermore, limiting supermatrix is calculated increasing the

supermatrix continuously until the numbers in each column in one row are the same. In ANP, consistency ratio (CR) is calculated to determine consistency from pairwise comparison, and if the CR value is higher than 10%, it is necessary to perform reassessment for the pairwise comparison.

The fourth stage is determining the priority risk agent based on Aggregate Risk Potential (ARP) value using the phase 1 of HOR. In this phase, the severity value is generated from the ANP procedure in the third stage, and the Probability Risk agent HOR value is generated from the assessment in the PIM procedure. Risk events and risk agents relationship were assessed on a scale of 0 (no relationship), 1 (low relationship), 3 (medium relationship), and 9 (high

relationship). ARP of each risk agent is calculated based on severity, probability, and relationship risk events and risk agents. The fifth stage is determining the priority of the mitigation strategy using the phase 2 of HOR. Preventive action for mitigation strategy is obtained through focus group discussion. The Total Effectiveness (TE) is based on ARP on risk agent, the relationship between risk agent, and preventive action (PA). Risk agents and preventive action relationships were assessed on a scale of 0 (no relationship), 1 (low relationship), 3 (medium relationship), and 9 (high relationship). Difficulty (D) of preventive action is graded from 1 (easy) to 4 (very difficult). The highest Effectiveness to Difficulty Ratio (ETD) is a priority mitigation value based on the ratio of TE to D.

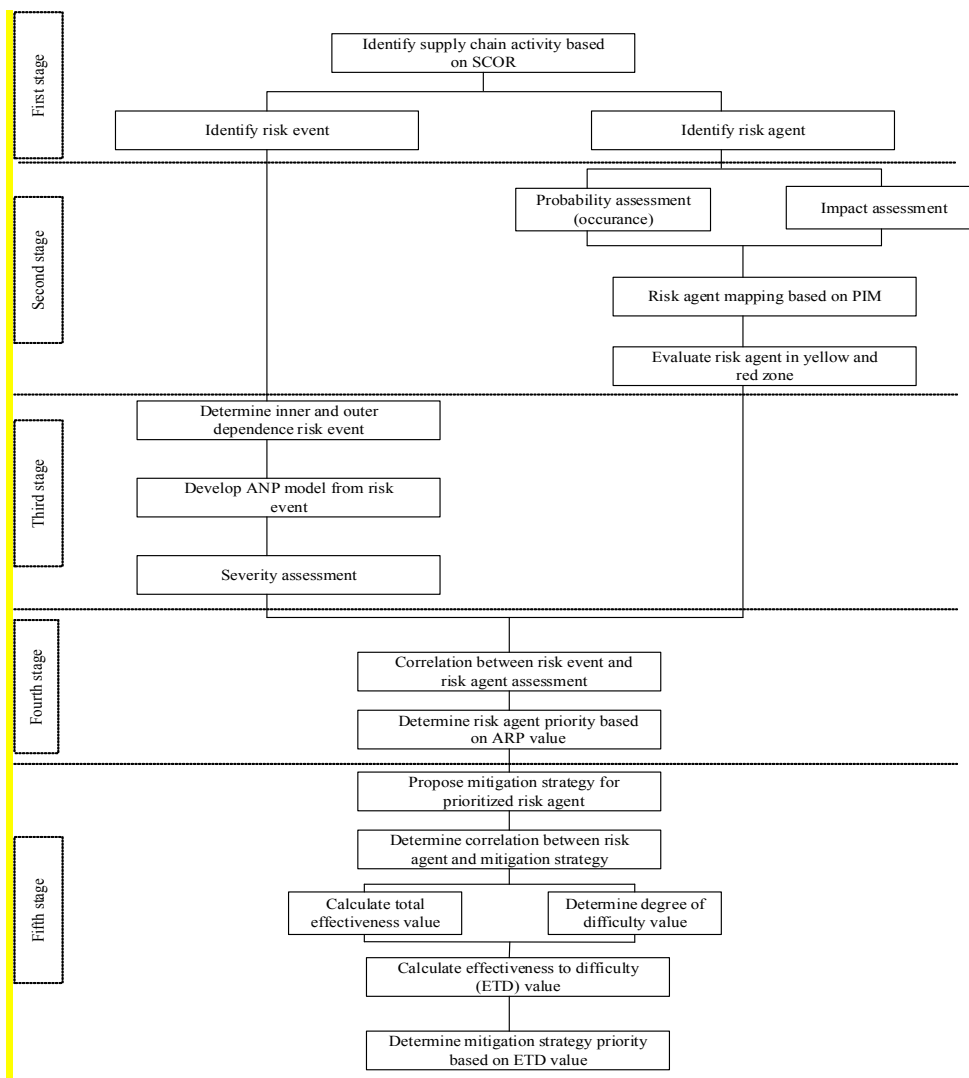

Fig. 1. Research framework

2.2. Data and case study

In this study, the proposed framework is applied to a case study of a palm oil processing company

in Indonesia. Three experts were involved to assess the risk impact, risk probability, pairwise comparison for severity of risk events, risk event

and risk agent relationship assessment, risk agent relationship assessment and mitigation strategy, and difficulty level assessment. Identification of risk events and risk agents in the supply chain of palm oil are presented in Table 1 and Table 2. Table 1 shows risk events corresponding to the clusters: there are 4 risk events in the cluster plan,

8 risk events in the source cluster, 6 risk events in the make cluster, and 5 risk events in the deliver cluster. Furthermore, Table 2 shows the risk agent corresponding to the cluster: there are 4 risk events in the cluster plan, 9 risk events in the source cluster, 4 risk events in the make cluster, and 6 risk events in the deliver cluster.

Tab. 1. Risk events in the supply chain of palm oil

Major process	Sub process	Risk event	Code
<i>Plan</i>	Production planning	Mismatch between capacity planning and realization process	E1
		Production costs do not match the initial budget plan	E2
	Machine maintenance planning	The machine suddenly broke	E3
	TBS delivery	Raw material stock is not as planned	E4
<i>Source</i>	TBS acceptance	Delay in delivery of TBS to the factory	E5
		Broken scale	E6
		Low TBS quality	E7
	Filling TBS to lori	Rotten/raw TBS pass sorting	E8
		The amount of TBS is less than the capacity of the conveyance	E9
		Piling of fresh fruit bunches on the platform	E10
<i>Make</i>	Production process	TBS damaged in storage/platform	E11
		Lorry broken	E12
		TBS is damaged so it can't be processed	E13
		There was a delay during production	E14
	<i>Quality control CPO</i>	Machine stop operating	E15
		Request cannot be fulfilled	E16
		CPO quality varies	E17
		No quality check during the production process	E18
<i>Deliver</i>	CPO storage in warehouse	CPO damaged in warehouse	E19
	Delivery of products to consumers	Lack of product delivery capacity	E20
		CPO delivery delay	E21
		CPO spilled during shipping	E22
		CPO tank car damaged	E23

Tab. 2. Risk Agents in The Supply Chain of Palm Oil

Major process	Sub process	Risk agent	Code
<i>Plan</i>	Production planning	The engine capacity cannot be maximized	A1
		Production target is too high	A2
	Machine maintenance planning	Error in machine maintenance schedule	A3
	TBS delivery	Production plan calculation error	A4
<i>Source</i>	TBS acceptance	Broken transport car	A5
		Excessive vibration	A6
		Broken loadcell	A7
	Filling TBS to lori	TBS storage in the open	A8
		TBS damaged during the shipping process	A9
		Delay in delivery of fruit from plantation	A10
<i>Make</i>	Production process	Many fruits enter the factory	A11
		Do not use the FIFO system (first in first out)	A12
		Broken lorry components	A13
	Production process	Does not consider machine setup time	A14
		An unplanned breakdown occurred	A15
		Labor negligence	A16

	Quality control CPO	defects during production	A17
	CPO storage in warehouse	The product has been in the warehouse for too long	A18
Deliver	Delivery of products to consumers	Delay in fulfilling customer orders	A19
		Limited transport truck facilities	A20
		Broken truck faucet	A21
		Transport truck hose broke	A22
		Unscheduled car maintenance	A23

3. Results and Discussion

3.1. Risk agent mapping with probability impact matrix

The risk agent mapping in the probability impact matrix is based on the risk probability and impact. The risk agent mapping in the supply chain of palm oil using PIM can be seen in Figure

2. The results concluded that there are 3 risk agents which are in green zone, 10 risk agents in the yellow zone, and 10 risk agents in the red zone. The risk agents that will be processed using HOR are those in the yellow and red zones because risks in these zones have bigger impact to the supply chain.

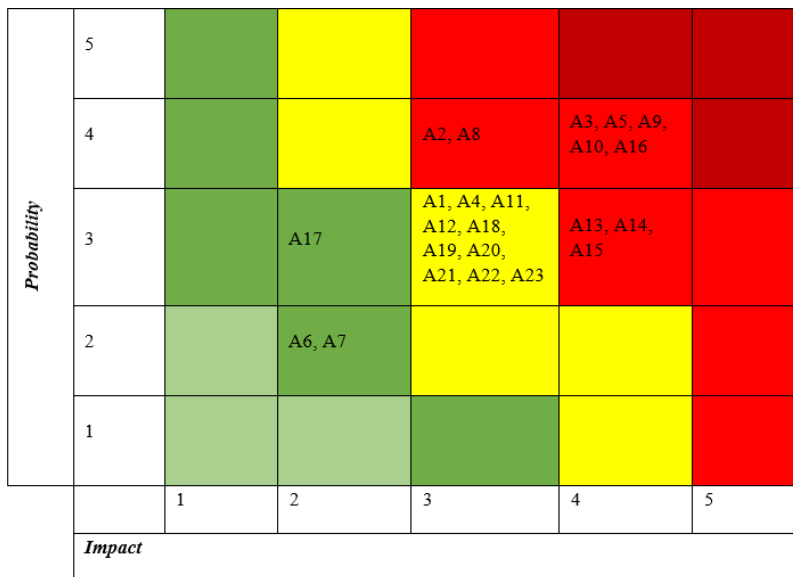

Fig. 2. Mapping risk agent using probability impact matrix

3.2. Assessment of the severity risk event using analytical network process

In ANP, a relationship between each risk event is needed to assess the severity of a risk event. A pairwise comparison based on the relationship between each risk event was carried out in ANP. Then, it was processed using the super decision software to obtain the severity value. Figure 3 shows the risk event relationship in the supply chain of palm oil. For example, the cluster plan has an inner dependence (influences each other within one cluster), namely the risk event “mismatch between capacity planning and the realization process” (E1) is influenced by “production costs not in accordance with the

initial budget plan” (E2), “errors in engine maintenance scheduling” (E3), and “raw material stock is not as planned” (E4). This means that E1 is influenced by E2, E3, and E4 while E2, E3, and E4 are influenced by E1. While the cluster plan's outer dependence (mutual influence between clusters), namely the risk event “mismatch between production planning and the realization process” (E1), is influenced by “TBS delivery to the factory” (E5) and “low TBS quality” (E7). The severity value-based ANP is presented in Table 3. It shows that “unscheduled car maintenance” (E23) has the highest severity value of 0.11 and “damaged scales” (E6) have the lowest severity value of 0.008.

[Downloaded from ijiepr.iust.ac.ir on 2026-05-31]

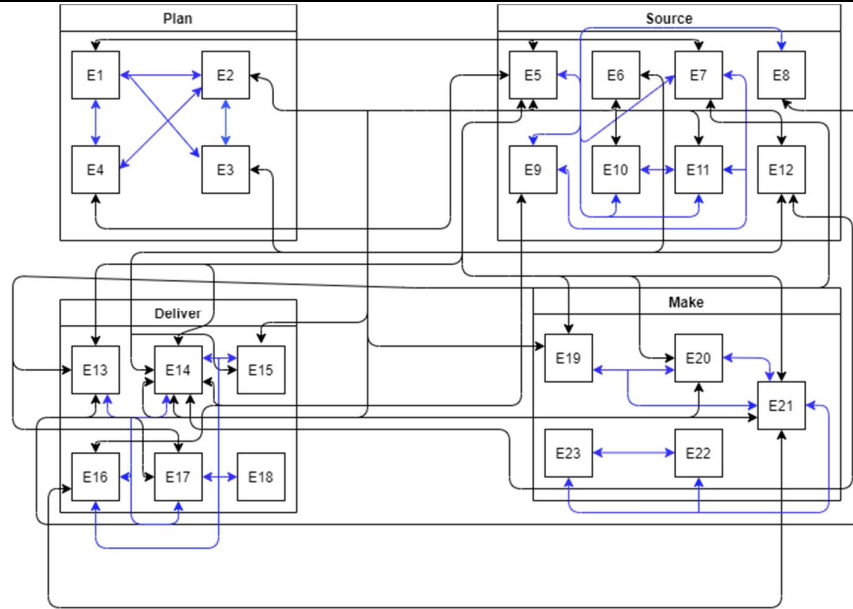

Fig. 3. Risk event relationship in the supply chain of palm oil

Tab. 3. Severity risk event value based on ANP

Code	Severity	Code	Severity	Code	Severity
E1	0.055	E10	0.039	E19	0.024
E2	0.061	E11	0.034	E20	0.047
E3	0.061	E12	0.021	E21	0.063
E4	0.061	E13	0.051	E22	0.057
E5	0.019	E14	0.067	E23	0.111
E6	0.008	E15	0.056		
E7	0.020	E16	0.027		
E8	0.038	E17	0.021		
E9	0.033	E18	0.014		

3.3. Determining the priority of risk agent with phase 1 of house of risk

Based on the severity assessment using ANP and risk agent mapping in PIM method, Agent Risk Priority (ARP) from phase 1 of HOR is presented in Table 4. This result show that the risk agent “unplanned breakdown occurred” (A15) has the

highest ARP. Then ARP ranking was performed using the 80:20 pareto principle, which means that 80% of the causes with the highest ARP values are prioritized first. By using the Pareto diagram, 10 risk agents are obtained which will be prioritized in determining the mitigation strategy as shown in table 6.

Tab. 4. Phase 1 of house of risk

Risk event	Risk agent																						Severity
	A1	A2	A3	A4	A5	A8	A9	A10	A11	A12	A13	A14	A15	A16	A18	A19	A20	A21	A22	A23			
E1	9	3	1	1			1					3	3	3								0,06	
E2	9	9	3	3							3	3	3									0,06	
E3	9	9						3			3	3	3									0,06	
E4					3		3	3														0,06	
E5					9		3															0,02	
E6																						0,01	
E7					3	3	9		9	3												0,02	
E8									9													0,04	

E9		1		3		9														0,03
E10						3	9	3	9		3									0,04
E11		1	1			3	9	9	9											0,03
E12													9							0,02
E13				1				3	3	3										0,05
E14						3				3	3	9								0,07
E15												9	9							0,06
E16														9						0,03
E17				1						3										0,02
E18																				0,01
E19												3	3	3	9					0,02
E20													3	3		9				0,05
E21															9	9				0,06
E22																	9	9		0,06
E23																			9	0,11
Probability	3	4	4	3	4	4	4	4	3	3	3	3	3	4	3	3	3	3	3	3
ARP	4,81	5,07	0,96	0,72	1,97	0,92	2,85	3,65	4,04	2,12	4,73	3,96	5,96	2,53	0,67	3,01	1,72	0,00	0,00	3,01
Rank	3	2	15	17	13	16	10	7	5	12	4	6	1	11	18	8	14	19	20	9

3.4. Determining the priority of the mitigation strategy phase 2 of house of risk
 Based on the ARP assessed in the previous stage, this section presents the determination of appropriate risk mitigation in the palm oil supply

chain. Determination of risk mitigation makes use of phase 2 of HOR. Proposed mitigation strategies for the palm oil supply chain is shown in Table 5. Assessment on phase 2 of HOR is presented in Table 6.

Tab. 5. Proposed mitigation strategies

Code	Proposed Mitigation strategy	References
PA1	Carry out maintenance of machines using predictive maintenance	(Selcuk, 2016)
PA2	Determine the interval for replacement of car spare parts	(Błażejowski et al., 2020)
PA3	Implementing collaborative planning forecasting replenishment (CPFR)	(Sherman, 1998)
PA4	Provide work instructions on each machine	-
PA5	Provide rewards and sanctions for workers who do not comply with the SOP	-
PA6	Using tarpaulin as a cover for TBS during the shipping process	-

Tab. 6. Assessment on phase 2 of hOR

Risk agent	Proposed Mitigation strategy						ARP
	PA1	PA2	PA3	PA4	PA5	PA6	
A15	9						5.96
A2			9				5.07
A1	3						4.81
A13	9			3	9		4.73
A11			9				4.04
A14	9			9	9		3.96
A10			9				3.65
A19			9				3.01
A23		9					3.01
A9			9			9	2.85

TE	146.29	27.07	167.61	49.82	78.21	25.60
D	3	3	3	4	4	3
ETD	48.77	9.02	55.87	12.46	19.55	8.54
Rank	2	5	1	4	3	6

Based on Table 6, applying collaborative planning forecasting replenishment (PA3) yielded the highest ETD value of 55.79. This strategy can overcome the risk agent production target is too high (A2), lots of fruit entering the factory (A11), late delivery of fruit from plantations (A10), delays in fulfilling consumer orders (A19) and damaged TBS during the delivery process (A9). CPFR is a concept where supply chain members collaborate in planning and fulfilling customer demand. In a previous study conducted by Ramdhanu & Hasibuan (2017), CPFR is proven to be able to solve almost the same problems as the company's risk agents, which are inventory problems, controlling capacity, eliminating delays in the delivery of raw materials and finished products. In the implementation of CPFR, the plantations and factories will work together in planning and fulfilling consumer demands. Carrying out maintenance of machines using predictive maintenance has an ETD value of 48.77. This strategy can overcome the risk agent of unplanned engine damage (A15), engine capacity cannot be maximized (A1), and damaged lorry components (A13). Predictive maintenance is a method of recognizing the potential damage before it happened. Previously, the company applied the concept of preventive maintenance, by replacing the components based on predetermined time intervals. However, in its application, the damage often occurs prematurely. Therefore, the researcher proposes implementing predictive maintenance so that the company can recognize the damage before it occurs.

Giving rewards and sanctions for workers who do not comply with the SOP has an ETD value of 19.55. This strategy can overcome the risk agent for damaged lorry components (A13). In its application, the company makes a work procedure document, then the company supervises the performance of employees in accordance with the work procedures that have been made. Giving work instructions on each machine has an ETD value of 12.46, which can overcome the risk agent for damaged lorry components (A13) and does not consider machine setup time (A14). Determination of the replacement interval for car spare parts has the largest ETD value of 9.02. This strategy can overcome the risk of unscheduled car maintenance agents (A23). Determination of the

replacement interval can use several methods, one of which is age replacement. Age replacement is a method that determines the maintenance time based on the time interval of the damage. Using a tarpaulin as a TBS cover during the shipping process has an ETD value of 8.54, this strategy can overcome the risk of the TBS agent being damaged during the shipping process (A9). The use of tarpaulin as a cover for TBS serves to prevent TBS from being exposed to rain during the shipping process. This is done to maintain the quality of TBS, TBS that has been exposed to rain has the potential to rot quickly.

4. Conclusion

This study attempts to propose a hybrid method for mitigating palm oil supply chain risks that includes PIM, ANP, and HOR procedures. According to the findings, the 20 risk agents posed medium (yellow) and high (red) risks. Unscheduled car maintenance (E23) has the highest severity rating with ANP, and damaged scales (E6) has the lowest. Unplanned breakdown occurred (A15) has the highest ARP value in risk agent based on phase 1 of HOR. Implementing collaborative forecasting replenishment (PA3) produces the highest priority value for risk mitigation in phase 2 of HOR, which consists of six mitigation strategies. Some of the limitations of this study include assuming that respondents' and experts' preferred answers are crisp. In fact, some answer preferences allow for some degree of ambiguity. As a result, research with fuzzy characteristics should be considered in future studies.

References

- [1] M. A. Kassem, M. A. Khoiry and N. Hamzah, Using probability impact matrix (PIM) in analyzing risk factors affecting the success of oil and gas construction projects in Yemen. *International Journal of Energy Sector Management*, Vol. 14, No. 3, (2019), pp. 527-546.
- [2] F. B. Ahmad, Z. Zhang, W. O. S. Doherty and I. M. O'Hara, The outlook of the production of advanced fuels and chemicals from integrated oil palm biomass biorefinery. *Renewable and Sustainable Energy Reviews*, Vol. 109,

- (2019), pp. 386-411.
- [3] H. Aini, M. Syamsun and A. Setiawan, Risiko rantai pasok kakao di Indonesia dengan metode analytic network process dan failure mode effect analysis terintegrasi. *Jurnal Manajemen & Agribisnis*, Vol. 11, No. 3, (2014), pp. 209-219.
- [4] A. R. Anugerah, S. A. Ahmad, R. Samin, Z. Samdin and N. Kamaruddin, Modified failure mode and effect analysis to mitigate sustainable related risk in the palm oil supply chain. *Advances in Materials and Processing Technologies*, (2021), pp. 1-15.
- [5] R. Błażejowski, R. Matz, T. Nawrot and D. Rudzik, Reliability and optimal replacement interval of flexible hose assemblies in drinking water installations. *Engineering Failure Analysis*, Vol. 109, (2020), p. 104327.
- [6] W. Boonyanusith and P. Jittamai, Blood supply chain risk management using house of risk model. *Walailak Journal of Science and Technology (WJST)*, Vol. 16, No. 8, (2019), pp. 573-591.
- [7] Z. D. Cahyani, S. R. W. Pribadi and I. Baihaqi, Studi implementasi model House of Risk (HOR) untuk mitigasi risiko keterlambatan material dan komponen impor pada pembangunan kapal baru. *Jurnal Teknik ITS*, Vol. 5, No. 2, (2016), pp. G52-G59.
- [8] R. A. Hadiguna and B. Tjahjono, A framework for managing sustainable palm oil supply chain operations: a case of Indonesia. *Production Planning & Control*, Vol. 28, No. 13, (2017), pp. 1093-1106.
- [9] F. Harahap, S. Leduc, S. Mesfun, D. Khatiwada, F. Kraxner and S. Silveira, Opportunities to Optimize the Palm Oil Supply Chain in Sumatra, Indonesia. *Energies*, Vol. 12, No. 3, (2019).
- [10] W. Ho, T. Zheng, H. Yildiz and S. Talluri, Supply chain risk management: a literature review. *International Journal of Production Research*, Vol. 53, No. 16, (2015), pp. 5031-5069.
- [11] M. F. Ibrahim, M. M. Putri and D. M. A. Utama, literature review on reducing carbon emission from supply chain system: drivers, barriers, performance indicators, and practices. *IOP Conference Series: Materials Science and Engineering*, Vol. 722, No. 1, (2020), p. 012034.
- [12] I. John, A. M. Magdalene, S. S. S. Tarmizi and J. T. Shirley, A Model to Manage Crude Palm Oil Production System. (Ed.), (2019).
- [13] M. A. Kassem, M. A. Khoiry and N. Hamzah, Using relative importance index method for developing risk map in oil and gas construction projects. *Jurnal Kejuruteraan*, Vol. 32, No. 3, (2020), pp. 441-453.
- [14] I. Kilubi, The strategies of supply chain risk management – a synthesis and classification. *International Journal of Logistics Research and Applications*, Vol. 19, No. 6, (2016), pp. 604-629.
- [15] S. Y. Lau, S. L. Phuan, M. K. Danquah and C. Acquah, Sustainable palm oil refining using pelletized and surface-modified oil palm boiler ash (OPBA) biosorbent. *Journal of Cleaner Production*, Vol. 230, (2019), pp. 527-535.
- [16] O. Lavastre, A. Gunasekaran and A. Spalanzani, Supply chain risk management in French companies. *Decision Support Systems*, Vol. 52, No. 4, (2012), pp. 828-838.
- [17] J. R. Macdonald, C. W. Zobel, S. A. Melnyk and S. E. Griffis, Supply chain risk and resilience: theory building through structured experiments and simulation. *International Journal of Production Research*, Vol. 56, No. 12, (2018), pp. 4337-4355.
- [18] R. Magdalena and V. Vannie, Analisis Risiko Supply Chain Dengan Model

- House of Risk (Hor) Pada Pt Tatalogam Lestari. *Jurnal Teknik Industri*, Vol. 14, No. 2, (2019), pp. 53-62.
- [19] K. Moreno-Sader, C. Alarcón-Suesca and A. D. González-Delgado, Application of environmental and hazard assessment methodologies towards the sustainable production of crude palm oil in North-Colombia. *Sustainable Chemistry and Pharmacy*, Vol. 15, (2020), p. 100221.
- [20] C. Natalia, C. W. Oktavia, T. P. Hidayat and W. Makatita, Risk management model development by integrating House of Risk model and ANP model. *Journal of Administrative and Business Studies*, Vol. 6, No. 4, (2020), pp. 138-149.
- [21] I. Nyoman Pujawan and L. H. Geraldin, House of risk: a model for proactive supply chain risk management. *Business Process Management Journal*, Vol. 15, No. 6, (2009), pp. 953-967.
- [22] C. W. Octavia, R. Magdalena and W. Prasetya, Implementasi House of Risk dalam Strategi Mitigasi Penyebab Risiko pada Aktivitas di Bagian Produksi PT. XYZ. *Jurnal Metris*, Vol. 20, No. 01, (2019), pp. 58-70.
- [23] S. Prakash, S. Sandeep Gunjan and A. Rathore, Supply Chain Operations Reference (SCOR) model: an overview and a structured literature review of its application. (Ed.),^(Eds.), (2013).
- [24] A. Priyambada, Manajemen Risiko dan Analisis Keputusan Solusi Material Obsolete Mechanical Menggunakan Metode HOR dan ANP (Studi Kasus: PT XYZ). *Journal of Industrial Engineering Management*, Vol. 5, No. 1, (2020), pp. 1-9.
- [25] L. E. Rincón, J. Moncada and C. A. Cardona, Analysis of potential technological schemes for the development of oil palm industry in Colombia: A biorefinery point of view. *Industrial Crops and Products*, Vol. 52, (2014), pp. 457-465.
- [26] L. E. Rincón, M. J. Valencia, V. Hernández, L. G. Matallana and C. A. Cardona, Optimization of the Colombian biodiesel supply chain from oil palm crop based on techno-economical and environmental criteria. *Energy Economics*, Vol. 47, (2015), pp. 154-167.
- [27] T. L. Saaty and L. G. Vargas, The Analytic Network Process. In T. L. Saaty & L. G. Vargas (Eds.), *Decision Making with the Analytic Network Process: Economic, Political, Social and Technological Applications with Benefits, Opportunities, Costs and Risks* (2013), pp. 1-40.
- [28] E. S. M. Anggraeni and I. Sailah, (2019, 20-21 September 2018). Operational risk evaluation and mitigation for palm oil supply chain: a case study at x co. (Ed.),^(Eds.). International Conference on Digital Agriculture from Land to Consumers (ICDALC 2018) Bogor, Indonesia.
- [29] S. Selcuk, Predictive maintenance, its implementation and latest trends. *Proceedings of the Institution of Mechanical Engineers, Part B: Journal of Engineering Manufacture*, Vol. 231, No. 9, (2016), pp. 1670-1679.
- [30] R. J. Sherman, Collaborative Planning, Forecasting & Replenishment (CPFR): Realizing the Promise of Efficient Consumer Response through Collaborative Technology. *Journal of Marketing Theory and Practice*, Vol. 6, No. 4, (1998), pp. 6-9.
- [31] R. Sreedevi and H. Saranga, Uncertainty and supply chain risk: The moderating role of supply chain flexibility in risk mitigation. *International Journal of Production Economics*, Vol. 193, (2017), pp. 332-342.
- [32] W. N. Tanjung, R. S. Khodijah, S. Hidayat, E. Ripmiatin, S. A. Atikah and S. S. Asti, (2019, 27-29 November 2018). Supply Chain Risk Management on Wooden Toys Industries by using House of Risk (HOR) and Analytical Network

- Process (ANP) Method. (Ed.),^(Eds.). 11th ISIEM (International Seminar on Industrial Engineering & Management, Makasar, South Sulawesi, Indonesia.
- [33] N. Umami, P. F. Ferdinant, A. Irman and A. Gunawan, Integration house of risk and analytical network process for supply chain risk mitigation of cassava opak chips industry. (Ed.),^(Eds.), (2018).
- [34] D. M. Utama, I. Santoso, Y. Hendrawan and W. A. P. Dania, Integrated procurement-production inventory model in supply chain: A systematic review. *Operations Research Perspectives*, Vol. 9, (2022), p. 100221.
- [35] M. Yetrina, Pengembangan Algoritma Manajemen Risiko Proyek Konstruksi. *Jurnal Optimasi Sistem Industri*, Vol. 17, No. 1, (2018), pp. 101-112.

Follow this article at the following site:

Nur Afni A Kutanga, Annisa Kesy Garside & Dana Marsetiya Utama. A Hybrid Method for Risk Mitigation Strategy on Palm Oil Supply Chain: A Case Study in Indonesia. *IJIEPR* 2023; 34 (1) :1-11

URL: <http://ijiepr.iust.ac.ir/article-1-1565-en.html>

