



# Experimental Analysis of CNC Turning of Nylon Using Taguchi Method

Sujit Kumar Jha \*

*Sujit Kumar Jha, Engineering Department, Ibra College of Technology, Ibra, Sultanate of Oman*

## KEYWORDS

Taguchi method,  
Optimization,  
CNC Turning,  
Cutting Parameters,  
MRR

## ABSTRACT

*Manufacturing process frequently employs optimization of machining parameters in order to improve product quality as well as to enhance productivity. The material removal rate is a significant indicator of the productivity and cost efficiency of the process. Taguchi method has been implemented for assessing favorable (optimal) machining condition during the machining of nylon by considering three important cutting parameters like cutting speed, feed rate and depth of cut during machining on computer numerical control (CNC). The objective of the paper is to find out, which process parameters having more impacts on material removal rate during turning operation on nylon using analysis of variance (ANOVA). An Orthogonal array has been constructed to find the optimal levels of the turning parameters and further signal-to-noise (S/N) ratio has been computed to construct the analysis of variance table. The results of ANOVA shown that feed rate has most significant factor on material removal rate (MRR) compare to cutting speed and depth of cut for nylon. The confirmation experiments have conducted to validate the optimal cutting parameters and improvement of MRR from initial conditions is 555.56%.*

© 2016 IUST Publication, IJIEPR. Vol. 27, No. 2, All Rights Reserved

## 1. Introduction

In today's competitive era, manufacturers are given more emphasis to maintain the quality of product at low cost. Increasing competition and structural unsteadiness compels the manufacturers to improve the productivity as well as quality of the product. Here, quality and

productivity are two contradictory terms of company's performance. Quality of a product directly related to the customer's satisfaction whereas productivity directly related to profit of an organization. During machining operations quality of a product concerned with surface finish and dimensional accuracy whereas productivity concerned to Material Removal Rate (MRR). Productivity can be improved by reduction in machining time which may results loss in quality. Metal-based industries have main objective to produce high quality product with improved

\* Corresponding author: Sujit Kumar Jha  
Email: [skjha@ict.edu.om](mailto:skjha@ict.edu.om)

Received 22 June 2015; revised 13 June 2016; accepted 15 July 2016

productivity during manufacturing products. The high speed machining (HSM) and modern machining technologies are being used to machine the parts that need significant amount of material removal. Turning is the machining process in which a single point cutting tool removes unwanted material from the surface of a rotating cylindrical work piece [1]. In turning, selection of cutting parameters is important task for increasing the productivity. The cutting parameters like cutting speed, feed rate, depth of cut, coolant condition and tool geometry affects the material removal rate in turning.

The choice of Computerized Numerical Control (CNC) manufacturing process is based on optimization of cost, increased in productivity and improvement of quality of the product by precision manufacturing. CNC machine is capable of achieving the desired turning operation by high accuracy and very low processing time. There are many mathematical models have been formulated based on statistical regression for proper selection of cutting parameters and establish the relationship between the cutting parameters and cutting performance [2-5]. In this paper, Taguchi method has been implemented as another approach to find out the desired cutting parameters more competently [6, 7]. Paper has selected three cutting parameters that is cutting speed, depth of cut and feed rate to optimize the MRR during turning processes, which further can be assess by the cost of the manufactured product, productivity or some other criterion. Recently, several researchers have worked on the optimization of cutting parameters for optimal MRR and surface roughness. Some researchers work on setting up optimum cutting speeds in CNC machining have discussed the process parameters need to be optimized during CNC machining is an essential and costly process for small and medium type manufacturing industries [8 – 10]. Yang and Tarn [2] analyzed the cutting parameters based on the cutting characteristics of S45C steel using Taguchi method and ANOVA analysis for determination of optimal cutting parameters. Ahmet [11] analyzed the process parameters for surface roughness on aluminum material in pocket machining and observed that surface roughness correlates negatively with cutting speed and positively with feed and depth of cut. Some researchers have studied the influence of process parameters on performance of various aspects of machining like: tool life, tool wear, interaction of cutting forces, surface roughness, material removal rate, machine tool chatter and vibration

etc [12–15]. Ezugwu and Okeke [16] have investigated the machining of nickel based C-263 alloy at high speed using titanium nitride coated carbide inserts. They have found that the significance of feed rate is more than depth of cut in terms of tool performance and its life during machining operation. The experimental analysis to determine the variation of machining parameters on MRR, gap width and surface roughness has been analyzed and presented in graphical form by Liao et al., [17]. Lok and Lee [18] have been evaluated the machining performance in terms of MRR and surface roughness by experimental analysis on ceramics using wire electrical discharge machining.

There are two objective of this paper to investigate process parameters for a turning nylon work piece on EMCO CNC turning machine. The first is to demonstrate a methodical process of using Taguchi parameter design in turning process. The second is to demonstrate the use of Taguchi parameter design in order to find out the optimum MRR with a particular combination of cutting parameters in a turning operation. The statistical analysis techniques have been used to assess the impacts of cutting parameters on MRR. The proper selection of process parameters is essential for getting high cutting performance. The cutting parameters are reflected on MRR, which is used to determine and to evaluate the productivity of a turning product.

The structure of the paper is as follows. Section 2 described in details Taguchi Method, section 3 demonstrated Study of material and experimental setup for this research followed by Data analysis results and discussions in section 4. Finally, section 5 presents conclusions.

## 2. Taguchi Method

Taguchi method is statistical method developed by Professor Genichi Taguchi of Nippon Telephones and Telegraph Company Japan for the production of robust products. According to Taguchi, total loss generated by a product to the society after shipped is the quality of the manufactured product. Taguchi has used experimental design as a tool to make products more robust – to make them less sensitive to noise factors. According to Taguchi, by identification of easily controllable factors and their settings the process and product design can be improved. Currently, Taguchi method is applied to many sectors like engineering, biotechnology, marketing and advertising. Taguchi developed a method based on orthogonal array experiments, which reduced "variance" for the experiment with "optimum settings" of

control parameters. Hence, the optimal results can be achieved by implementing the combination of Design of Experiments (DOE) with optimization of control parameters. Signal-to-noise (S/N) ratio and orthogonal array are two major tools used in robust design. Signal to noise ratio, which is log functions of desired output measures quality with emphasis on variation, and orthogonal arrays, provide a set of well-balanced experiments to accommodate many design factors at the same time Park, Phadke, [19, 20].

The information regarding behavior of a given process can be determined by executing the experiments on it and further collecting data based on the plan of Taguchi method. The collected data from all the experiments have been analyzed and studied the effects of various design parameters. Orthogonal arrays employed by Taguchi method is an important technique for robust design, which allow the effects of several parameters can be determined efficiently with a small number of experiments. The deviation of the experimental value from the desired value can be determined by defining a loss function. The value of loss function is further transformed into a signal-to-noise ratio. Normally, the performance characteristic in the analysis has been divided into three categories, the higher – the - better, the nominal-the-better, and the smaller - the - better. According to S/N analysis, the S/N ratio has been computed for each level of process parameters. Despite of the categories of the performance characteristic, the larger the S/N ratio corresponds to the better performance characteristic for MRR. Further, a statistical analysis of variance (ANOVA) is performed to identify which process parameters are more significant. S/N ratio is expressed on a decibel scale. Followings are the concept behind the:

- Quadratic Loss Function – used to quantify the loss incurred by the user due to deviation from target performance.
- Signal-to-Noise (S/N) Ratio – used for predicting the field quality through laboratory experiments.
- Orthogonal Arrays (OA) – used for gathering dependable information about control factors with a reduced number of experiments.

Application of Taguchi's method for parametric design has been carried out to determine an ideal feed rate and desired force combination Although small interactions exist between a horizontal feed rate and desired force, the experimental results showed that surface roughness decreases with a slower feed rate and larger grinding force, respectively presented by Liu et al., [21].

Optimization aspects of machining processes detailed described and presented by Taguchi et al., [4]. Taguchi has been contributed in the area of quality loss functions (QLFs), orthogonal arrays (OAs), robust designs, and Signal-to-Noise (S/N) ratios. Generally, technicians on the shop floor applied this method to improve the products and the processes. The objective function used in the S/N ratio is maximized, which moves design targets toward the middle of the design space for having less effects of the external variation. By doing so a, large reduction in both part and assembly tolerances which are major drivers of manufacturing cost Taguchi et al., [4].

Antony et al. [22] have implemented Taguchi method experimental design for new product development by considering 14 design parameters to optimize the manufacturing processes and improved customer satisfaction. According to Zhang et al., [23] Taguchi method also allows controlling the deviation caused by the uncontrollable factors, which has not been included at the conventional design of experiment. The number of controllable cutting parameters during the experiment is based on orthogonal array (OA), which analyses the data and finally identify the optimal condition Abuelnaga and Dardiry, [6]. Taguchi method uses S/N ratio as a response of the experiment, which can be measured when uncontrolled noise factors are present in the system Antony and Kaye, [24]. Noise is the outcome of the quality characteristics of the effect of external factors under test. S/N ratio described as the preferred signal ratio for the undesired random noise value. Taguchi recommends the use of S/N ratio to measure the quality characteristics deviating from the preferred value. The S/N ratio for each level of process parameters has been computed and further determined the highest S/N ratio for the result irrespective of the type of the quality characteristics. A high value of S/N ratio means the signal is much higher than the random effect of noise factors. There are three categories of quality characteristics during analysis of the S/N ratio are given as:

- Nominal-the-Best (NB) – closer to the target value is better, example diameter of a shaft.
- Lower-the-Better (LB) – it predict values pessimistically by including defects like surface roughness, pin holes or unwanted by-product.
- Higher-the-Better (HB) – larger the better characteristics includes the desired output as bond strength, material removal rate, employee participation and customer acceptance rate.

In Taguchi method, an orthogonal array has been designed to compute the main parameters placed at different rows influence on the result and interaction effects through a minimum number of experimental trials Ross, [25]. The S/N ratio has been used to measure the performance characteristics of the levels of control factors against these factors. The category the larger-to-the-better was used to calculate S/N ratio for material removal rate according to the equation:

$$S / N = -10 \log_{10} \left( \frac{1}{n} \sum_{i=1}^n \frac{1}{y_i^2} \right) \quad (1)$$

Where n is the number of values at each trial and  $y_i$  is the each observed value.

In addition, a statistical Analysis of Variance (ANOVA) has been used to determine the significance of the cutting parameters, and also to observe which parameters are significantly affecting the responses. The implementation of conventional experimental design methods are very difficult due to its complicacy and required more number of experiments by increasing the process parameters described by Kaladhari and Subbaiah, [26]. Taguchi method minimizes the number of experimental trials, by implementing a particular design of orthogonal arrays to study the entire parameter space with small number of experiments.

### 2-1. Steps Involved in Taguchi Method

For larger-the-better characteristics, Taguchi method have been used for a parameter design includes the following steps Nian et al., [27]:

1. Select a suitable output quality characteristic to be optimized.
2. Select the control factors and their levels, identify their possible interactions.
3. Select noise factors and their levels.
4. Select sufficient inner and outer arrays. Control factors assigned to inner array and noise factors to the outer array.
5. Carry out the experiment.
6. Execute statistical analysis based on S/N ratio. Predict optimal output performance level based on optimal control factor level combination, and conduct a confirmation experiment to verify the result.

### 3. Study of Material and Experimental Setup

There are many researchers illustrated the statically developed systems and models focused on cutting parameters significance on materials like stainless steel, carbon steel, cast iron, copper and aluminum, whereas few researches have been

available on nylon. The impact of cutting parameters on MRR for polymer materials has not been reported so far. Nylon is a special kind of polymer material having different mechanical and dimensional properties compares to ferrous and non-ferrous materials. There are two common grades of nylons commonly used are Nylon 6 and Nylon 6/6. The number represents the number of methyl groups presented on each side of the nitrogen atoms (amide groups). Nylon can also be known as polyamide, as amide groups are present on the polymer chain. The properties of nylon can vary by difference in number of methyl groups present. Nylon has good heat resistance, excellent chemical and wear resistance and easy to process. Normally, casts and extruded nylon are used in a wide range of industrial applications due to its mechanical properties including high wear and abrasion resistance, superior strength and stiffness. The major applications of nylon are as electric connectors, gear, cams, cable ties, film packaging, fluid reservoirs, automotive oil pans and sports equipment. The analysis of surface roughness during turning operation has been discussed in details for cast nylon 6 using fuzzy logic system Bandit, [28]. Bandit [29] has investigated the influence of cutting conditions on main cutting force and surface roughness in cast nylon turning operation. He has concluded after experimental analysis that main cutting force were increased by increasing of cutting speed and depth of cut whereas surface roughness is affected by increasing of feed rate. In this research, sample of nylon bars having dimension of diameter 40 mm and length of 124.5 mm (cutting length 40 mm) has been used as work-piece material. Due to the presence of different surface texture, color and refractive index, there is difficulty of machining nylon with single cutting tool. For improved quality of machining on nylon following criteria of tool should satisfy:

Sharp Tool – nylon is very abrasive and creates a great deal of heat so need re-sharpen often.

Radius on Tool – for pointed tool lines will come on the surface and a poor surface finish. Instead of having a sharp point better to put a radius on the end like 0.0625 to 0.125.

High speed and feed – give good surface finish  
Nylon does not carry heat off like a metal part, so too much heat between tool and surface gives a problem.

### 3-1. Machining of Nylon

Experiment has been carried out in drying machining of nylon 6 on EMCO CNC turning lathe. Nine work-pieces made of nylon 6 have been used in this study

with 40 mm diameter and 124.5 mm length. The triangular single point tool of insert material titanium carbide has been used in turning for optimal results. Machinability of nylon 6 depends on the physical and mechanical properties of the fibers present and its orientation. Machining operations can induce internal stress within work-piece. Improper machining or removal of large amounts of material can generate huge internal stresses that can further produce distortion and dimensional instabilities in the work-piece. For satisfactory surface finish on nylon, tool with honed sharp and have high rake and clearance angles used to minimize cutting force and reduce heat build-up. Chips will be continuous and stingy. Many researchers have worked on machining and machinability of polymeric materials due to its increasing utilizations. According to Kabayashi, [30] for good surface finish of plastics materials during machining operation it is required to generate

continuous chips for low heat generation and deformation instability. It is important to have in-depth knowledge for better understanding of machining process behavior, parametric influence and their interactions to produce high quality finished product by considering surface finish, material removal rate, cutting force, etc. Generally, cutting tools having larger rake angle are more advantage to produce low heat and minimum deformation to the surfaces. The microstructure of nylon has been studied through ViewMet Inverted microscope provided with Nikon Eclipse MA100 inverted microscope and ISO camera with internal power supply of 6V/30W halogen bulbs. The Figure 1 (a) shows the microstructure of nylon 6 after turning operation and (b) represents the variation of color values of a pixel in a line with lens magnification of 10X.

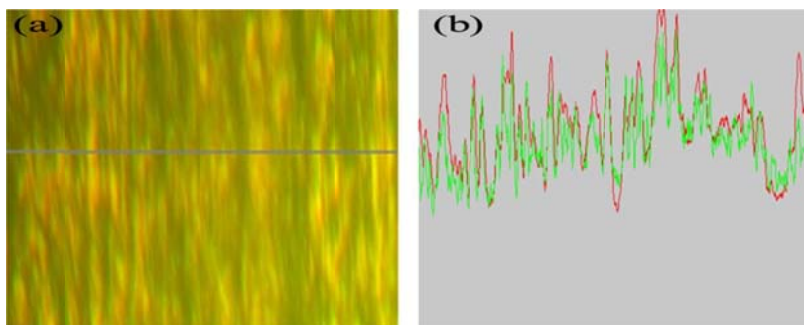

Fig. 1. (a) Represent the microstructure of nylon 6 and (b) shows the color values variation in a line

**3-2. Experimental set-up and cutting conditions**

According to Gaitonde et al., [31] high MRR is always desirable for increasing the productivity.

The details of experiments, experimental variables and constants have been shown in the Table 1.

**Tab. 1. Experimental details**

Details of the Experiment	Experimental Variables	Experimental Constants
Machine used: EMCO CNC Turns 250 machine		
Work-piece material: Nylon		
Density of material: 1700 kg/m <sup>3</sup>		
Diameter of Work Piece: 40 mm	Speed	Work Piece: Nylon
Hardness of Material: 17.8 HRF	Feed	Cutting condition
Tool material: Insert (Titanium Carbide)	Depth of Cut	CNC machine
Shape of Cutting Tool: Triangle		Cutting Tool material
Cutting Condition: Dry Machining		

This paper has considered three cutting parameters: cutting speed, feed and depth of cut for three levels. Due to the studied of three controlling factors for three levels, there are nine experiments were designed and conducted based on Taguchi's L9 orthogonal array. The experiments were conducted on EMCO CNC turning machine, which is highly versatile and up to date with the latest CNC technology, driven by latest CNC control system. EMCO Concept Turn 250 has a TCM 'C Axis' option with 6 driven

tools – power 1.2 kw, 200 – 6000 rpm and 'C' axis for main spindle, 0-1000 rpm allowing milling operations and simultaneous complex axes cutting work to take place at the same time. The experiments were conducted on standardized shown below Figure 2 the configuration of the machine as listed. Industrial design: 2 axes slant bed lathe, Tool Turret: 12 station VDI automatic tool changer optional 6 driven tool, Max turning diameter: 85 mm, Distance between centre 405 mm, Travel X Z: 100\*250 mm, Spindle speed: 60

– 6300 rpm, Max bar stock diameter: 25.5 mm, Feed force: 0-3 N and Display: 12" LCD. The material removal rate plays an important role during turning operation.



Fig. 2. EMCO Concept Turn 250

**3-3. Selection of cutting parameters and their levels**

The cutting experiment has been done on nylon material on EMCO CNC machine. Cutting speed, depth of cut and feed rate are considered as the control factors. The initial cutting parameters have been taken as cutting speed of 1500 RPM, a feed rate of 0.15 mm/rev, and a depth of cut 0.5 mm. The cutting parameters and their levels of this experiment are shown in Table 2.

**Tab. 2. Cutting Parameters and their levels**

Process parameters	Symbol	Unit	Level 1	Level 2	Level 3	Mean of parameters
Cutting speed	A	RPM	1000	1500	2000	1500
Feed rate	B	mm/rev	0.10	0.15	0.25	0.17
Depth of cut	C	mm	0.5	1.0	1.5	1.0

**3-4. Experimental methodology**

The component has drawn in AutoCAD 11 and shown in the Figure 3 (a). The program has prepared for turning operation and has been checked for its accuracy by using a simulation in

computer and simulated screen has shown in the Figure 3 (b). Experiments have been designed and carried out using Taguchi’s L9 Orthogonal Array (OA).

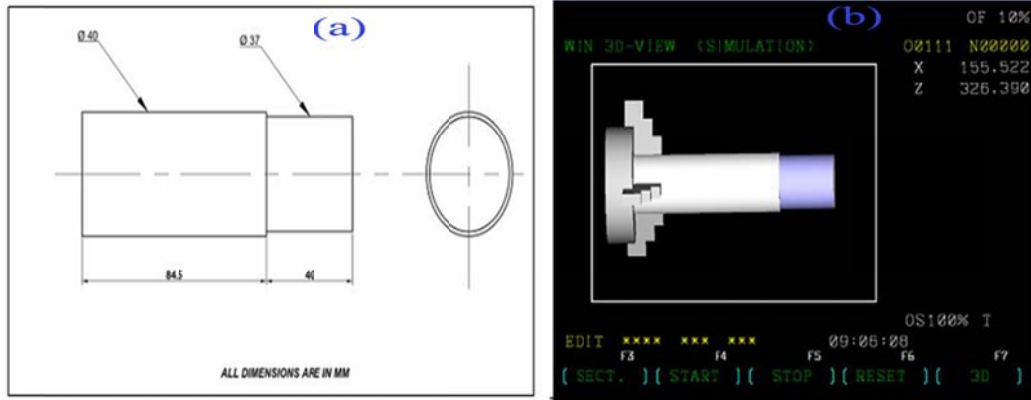

Fig. 3. (a) Profile Turning (b) Simulation on machining

In this research, a 3 factor three level factorial technique has been implemented for the development of design matrix to conduct the experiments, refers in Table 3 to represent the orthogonal array for our experiment. The objective of this research to obtain a mathematical model that relates the material removal rate to three cutting parameters in CNC turning process. The objective of using the S/N ratio as a performance measurement is to develop products and process insensitive to noise factor. The sample calculations for the first experiment

are shown below. The quality of product can be improved by proper selection and specific control of the variable process parameters. Zhang et al. implemented the Taguchi robust technique combined with the ANOVA to examine the factors influencing the surface quality in a CNC face milling operation. For machining of nylon, three controllable process parameters – spindle speed, feed and depth of cut have been chosen and been allowed to vary in three different levels (Table 2). Taguchi’s philosophy has been explored for adapting a framework for

experimental design and its execution.  $L_9$  orthogonal array has been adopted for this experimental set up has been computed of MRR and S/N ratios are tabulated in Table 4. Here, to assess the optimal condition spindle speed, feed and depth of cut has been considered as machining parameters.

#### 4. Data analysis Results and Discussion

An orthogonal array has been used to find out the optimal cutting parameters in reduce number of cutting experiments. The results of an orthogonal array have been further studied by using S/N ratio and ANOVA analyses. The optimal cutting parameters have been determined from the results of S/N ratio and ANOVA analyses.

##### 4-1. Orthogonal array experiment

To find out the suitable orthogonal array for experiments is based on the degrees of freedom. The degrees of freedom can be defined by comparisons between process parameters that required to be completed to find which level is better and how much it is. For example, three level process parameters have two degrees of freedom. The experimental layout for the cutting parameters has been shown in Table 3.

The degrees of freedom associated with the interaction between two process parameters are determined by the product of the degrees of freedom of two process parameters. In this research, the interaction between two process parameters has been neglected. After getting the degrees of freedom, next step is to select a proper orthogonal array to fit for the task. Normally, the degrees of freedom for the orthogonal array should be greater than or at least equal to those for the process parameters. In this paper, an  $L_9$  orthogonal array has six degrees of freedom ( $DOF = 3 \times (3-1) = 6$ ) has been used to handle 3-level process parameters. Each cutting parameters

are assigned to a column, nine cutting parameters are being available. Therefore, only 9 experiments are required to study the entire parameter space using the  $L_9$  orthogonal array.

**Tab. 3. Experimental layout using an  $L_9$  orthogonal array**

Experimental No.	Cutting parameter level		
	Cutting Speed (RPM)	Feed Rate (mm/rev)	Depth of cut (mm)
1	1	1	1
2	1	2	2
3	1	3	3
4	2	1	3
5	2	2	1
6	2	3	2
7	3	1	2
8	3	2	3
9	3	3	1

##### 4-2. Analysis of the signal-to-noise (S/N) ratio

In the Taguchi method, the term 'signal' implies the desired value (mean) for the output characteristic and the term 'noise' implies the undesirable value (S.D.) for the output characteristic. So, the S/N ratio defined as the ratio of the mean to the S.D. In Taguchi method, S/N ratio has been used to measure the quality of characteristic deviating from the desired value. As mentioned earlier, there are three categories of performance characteristic, namely, lower-the-better, higher-the-better, and nominal-the-better. To get optimal machining performance, the higher-the-better performance characteristic for MRR has been taken. Table 4 shows the experimental results for MRR and corresponding S/N ratio using Eq. (1) and then separate out the effect of each cutting parameter at different levels.

**Tab. 4. Experimental results for MRR and S/N ratio**

Exp. No.	Control Parameter (Level)				Result / Observed Value			
	Speed (RPM)	Feed (mm/rev)	Depth of Cut (mm)	Cutting Speed (m/min)	Cycle Time to Remove Material (sec)	MRR (gm/min)	MRR (mm <sup>3</sup> /min)	S/N Ratio (dB)
1	1000	0.10	0.5	125.6	186	4.97	2924.67	69.32
2	1000	0.15	1.0	125.6	72	12.84	7555.39	77.57
3	1000	0.25	1.5	125.6	35	26.42	15542.52	83.83
4	1500	0.10	1.0	188.4	70	13.21	7771.26	77.81
5	1500	0.15	1.5	188.4	38	24.34	14315.48	83.12
6	1500	0.25	0.5	188.4	52	17.78	10461.31	80.39
7	2000	0.10	1.5	251.2	43	21.51	12650.89	82.04
8	2000	0.15	0.5	251.2	38	24.34	14315.48	83.12
9	2000	0.25	1.0	251.2	19	48.67	28630.96	89.14

The total mean S/N ratio = 81.01 dB

Machining time required to reduce the diameter of nylon from 40 mm to 37 mm for each experiment has been observed and materials removed has been calculated as 12.24 Gms for each experiment. Material removal rate (MRR) can be calculated using the difference of weight of work piece before and after the machining operation.  $MRR = \frac{W_i - W_f}{\rho t}$

where,  $W_i$  is the initial weight of the work piece in grams,  $W_f$  is the final weight of the work piece in grams,  $\rho$  is the density of the material in

grams / mm<sup>3</sup>, and  $t$  is the time taken for machining. In practice MRR should be high, thus Taguchi method refers to select the process parameter having more S/N ratio.

The response table, which contains the sums of the S/N ratios for each level and for each factor is shown in the Table 5. For example, the sum of S/N ratio for cutting speed at levels 1, 2, and 3 can be calculated by adding the S/N ratio for the experiments 1-3, 4-6, and 7-9. The sum of S/N ratio for each level of the other cutting parameters has been computed in similar manner.

**Tab. 5. S/N ratio response table for each factor**

Factors	Depth of Cut (mm)	Feed rate (mm/rev)	Cutting Speed (m/min)
Level 1	232.83	229.17	230.72
Level 2	244.52	243.81	241.32
Level 3	248.99	253.36	254.3
Difference	16.16	24.19	23.41
Total	726.34	726.34	726.34

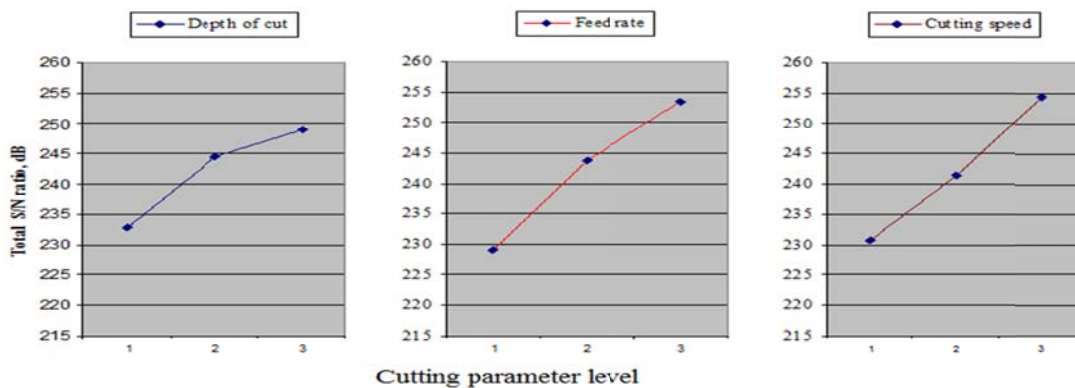

**Graph 1. S/N ratio graph for MRR**

Graph 1 show the total S/N ratio corresponds to each level for MRR. From Table 5 and Graph 1, all level totals are compared and combination yielding the highest combined S/N ratio is

selected for maximum metal removal rate. In this experiment, S3-F3-D3 combination yields the maximum metal removal rate. This is the optimal levels combination of factors for turning



operation in CNC for nylon material. Then the average S/N ratio for cutting speed at levels 1, 2, and 3 can be computed by averaging the S/N

ratios for the experiments 1-3, 4-6, and 7-9, which is denoted by MS<sub>1</sub>, MS<sub>2</sub>, and MS<sub>3</sub>. MS<sub>1</sub> is given by:

$$MS_1 = \frac{1}{3} \sum S / N \text{ ratio for the first level speed} = \frac{1}{3} (69.32 + 77.57 + 83.83) = 76.91$$

Similarly the MS<sub>2</sub> and MS<sub>3</sub> are calculated and are shown in the table below table. MF<sub>1</sub>, MF<sub>2</sub>, MF<sub>3</sub> and MD<sub>1</sub>, MD<sub>2</sub>, MD<sub>3</sub> are the average S/N ratio for feed and depth of cut factor, for three levels 1,

2 and 3. The mean S/N ratio for each level of cutting parameters is calculate and presented in Table 6, called the mean S/N response table for MRR.

**Tab. 6. Response table to identify significance of machining parameter for MRR**

Machining Parameters	Symbol	Mean S/N Ratio (dB)			Significance of Machining Parameter Max-Min
		Level 1	Level 2	Level 3	
Cutting speed (RPM)	A	76.91	80.44	84.77*	7.86
Feed rate (mm/rev)	B	76.39	81.27	84.45*	8.06
Depth of cut (mm)	C	77.61	81.51	82.99*	5.38

**4-3. Analysis of Variance (ANOVA) for MRR**

The purpose of the ANOVA is to investigate which process parameter has more impacts on performance characteristic. This is achieved by minimizing the effect of signal-to-noise ratio, which is calculated by the sum of squared deviations from the total mean of the multi

response signal-to-noise ratio, into contributions by each of the process parameters and the error. First the total sum of the squared deviations (SS<sub>T</sub>) from the total mean (η<sub>m</sub>) of the S/N ratio can be calculated as:

$$\eta_m = \frac{1}{9} \sum \text{sum of all the } S / N \text{ ratio}$$

$$\eta_m = \frac{1}{9} [69.32 + 77.57 + 83.83 + 77.81 + 83.12 + 80.39 + 82.04 + 83.12 + 89.14] = 81.01$$

$$SS_T = \sum_{i=1}^n (\eta_i - \eta_m)^2$$

where, n is the number of experiments in the orthogonal array and η<sub>i</sub> is the mean S/N ratio for the ith experiment.

The total sum of the squared deviations SS<sub>T</sub> is decomposed into two sources: the sum of the squared deviations SS<sub>D</sub> due to each process parameters and the sum of the squared error SS<sub>E</sub>. Then mean square (MS) is calculated by dividing the degrees of freedom of a factor to the sum of squares due to each factor. The ‘effects of factor level’ is defined as the deviation it causes from the overall mean. The total degrees of freedom = number of experiments-1 = 9-1=8, whereas degrees of freedom for each factor = 3-1=2. Then, F-value for each parameter has been computed by dividing the mean of square deviations the mean of square error. The percentage contribution (%C) by each of the process parameter in the total sum of the squared deviations SS<sub>T</sub> can be used to evaluate the

importance of the process parameter change on the quality characteristic.

$$SS_D = \sum_{j=1}^k n_j (\bar{x}_j - \eta_m)$$

$$SS_E = SS_T - SS_S - SS_F - SS_D$$

Statically, there is a tool name F-test based on (Fisher, 1925) [32] to evaluate which process parameters have a significant role the performance characteristic has been used as Taguchi method cannot determine the effects of individual parameters on entire process. F-test can be performed by computing the mean of squared deviations SS<sub>D</sub> and then calculating mean of squared deviation (MS) by dividing SS<sub>D</sub>/degrees of freedom associated with the process parameter. Then F-value for each process parameter can be calculated as SS<sub>D</sub>/SS<sub>E</sub>. Normally, larger the F-value more effects on performance characteristic due. At last, percentage contribution of individual parameters can be determined using ANOVA

analysis. Table 7 shows the results of ANOVA analysis for MRR.

**Tab. 7. Results of the analysis of variance for MRR**

Factor	SS <sub>D</sub>	DF	MS	F	%C
Speed	94.04	2	47.02	46.1	38.67
Feed	99.73	2	49.86	48.88	41.01
Depth of Cut	47.31	2	23.65	23.19	19.46
Error	2.05	2	1.02		
Total	243.13	8			

The F-value and % C for feed rate is more in the table, which indicates that feed rate is significantly contributing towards machining performance than cutting speed and depth of cut. Therefore, based on S/N ratio and ANOVA analysis for MRR, the optimal cutting parameters for material removal rate has been found from Table 2 at level 3 as cutting speed 2000 RPM in level 3, feed 0.25 mm/rev in level 3 and depth of cut 1.5 mm in level 3. From above analysis, paper concludes that the factor feed rate has the most significant factor and its contribution to material removal rate is more. The next significant factor is cutting speed and least significant factor is depth of cut.

#### 4-4. Confirmation Tests

After selecting the optimum level of process parameters, the final step is to predict and verify the improvement in performance characteristic by using the optimum level cutting parameters. The estimated S/N ratio  $\eta_{predicted}$  using the optimal level of the process parameters can be computed as (Yang and Tang, 1988) [2]:

$$\eta_{predicted} = \eta_m + \sum_{i=1}^o (\eta_i - \eta_m) \quad \dots(2)$$

Where  $\eta_m$  is the total mean of the S/N ratio,  $\eta_i$  is the mean S/N ratio at the optimal level, and  $o$  is the number of main process parameters that affect the performance characteristic. The estimated S/N ratio using the optimal cutting parameters for MRR has been obtained and the corresponding MRR can be calculated by using Eq. (1). The measuring data and the actual S/N ratio of confirmation experiments are listed in Table 8. Table 8 shows the comparison between predicted MRR with the actual MRR using optimal cutting parameter. The increase of the S/N ratio from the initial cutting parameter to the optimal cutting parameter is 14.90 dB, which means that MRR is increased by about 5.556

times. Therefore, prior design and analysis for optimizing the cutting parameters required for optimum MRR.

**Tab. 8. Results of conformation test for MRR**

	Initial Cutting Parameter	Optimal Cutting Parameter	
		Predicted	Experiment
Level	A2B2C1	A3B3C3	A3B3C3
MRR (mm <sup>3</sup> /min)	4800		26666.7
S/N ratio (dB)	73.62	82.34	88.52
Improvement of S/N ratio = 14.90 dB			

## 5. Conclusions

This paper has discussed the application of Taguchi method and ANOVA analysis to find a optimal values of turning parameters like cutting speed, feed and depth of cut to achieve the optimum value of MRR in CNC turning of nylon. Taguchi's robust orthogonal array has been implemented to analyze for MRR. The experimental results based on S/N ratio approach and ANOVA analysis provides a systematic and efficient methodology for the optimization of cutting parameters for MRR. The result based on F-test shows that feed rate has more impact on performance characteristic than cutting and depth of cut. The best parameters for material removal rate have been found from Table 2 at level 3 as cutting speed 2000 RPM in level 3, feed 0.25 mm/rev in level 3 and depth of cut 1.5 mm in level 3. The confirmation experiments have been conducted to validate the optimal cutting parameters. The improvement of MRR from initial cutting parameters to the optimal cutting parameters is around 555.56%.

**Acknowledgement:** The authors wish to thank the Department of Mechanical Engineering in Ibra College of Technology for supporting this research and special grateful to Mr. Vidhu Kumar for his help with experiment preparation on EMCO CNC Machine.

## References

- [1] Rao PN. Manufacturing Technology, Tata McGraw Hill publication, India, (2008).
- [2] Yang WH, Tarng YS. Design optimization of cutting parameters for turning operations based on the Taguchi method, Journal of Materials Processing Technology, Vol. 84, (1998), pp. 122-129.

- [3] Taguchi G, Choudhary S, Wu Y. Taguchi's Quality Engineering Handbook, John Wiley & Sons Inc, New Jersey, (2005).
- [4] Taguchi G, El Sayed M, Hsaing C. Quality engineering and production systems, New York: McGraw-Hill, (1989).
- [5] Sujit Kumar Jha. Optimization of process parameters for optimal mrr during turning steel bar using taguchi method and ANOVA, International Journal Mechanical Engineering and Robotics Research, Vol. 3, Issue 2, (2014), pp. 231-243.
- [6] Abuelnaga AM, El-Dardiry MA. Optimization methods for metal cutting, International Journal of Machine Tool Design and Research, Vol. 24, No. 1, (1984), pp 11-18.
- [7] Chrystolouris G, Guillot M. A comparison of statistical and AI approaches to the selection of process parameters in intelligent machining, ASME-Journal of Engineering for Industry, Vol. 112, No. 2, (1990), pp. 122-131.
- [8] Sanjit Moshat, Saurav Data, Ashish Bandopadhyay, Pradip kumar Pal. Optimization of CNC milling process parameters using PCA based Taguchi Method, International Journal of Engineering Science and Technology, Vol. 2, No. 1, (2010), pp. 92-102.
- [9] Basim Khidhir, Bashir Mohamed. Study of cutting speed on surface roughness and chip formation when machining nickel-based alloy, Journal of Mechanical Science and Technology, Vol. 24, No. 5, (2010), pp. 1053-1059.
- [10] Sujit Kumar Jha, Sujit Singh and Shiv Ranjan Kumar. Experimental analysis of CNC turning using taguchi method, Proceedings of Third International Conferences on Advances in Mechanical Engineering, Delhi, India, DOI: 02.AETAME.2012.3.15, (2012), pp. 91-95.
- [11] Ahmet Murat Pinar. Optimization of process parameters with minimum surface roughness in the pocket machining of aa5083 aluminum alloy via taguchi method, Arabian Journal for Science and Engineering, Vol. 38, No. 3, (2013), pp. 705-714.
- [12] Kadirgama K, Noor MM, Rahman MM, Rejab MRM, Haron CHC, Abou-EI-Hossein KA. Surface roughness prediction model of 6061-T6 aluminum alloy machining using statistical method, European Journal of Scientific Research, Vol. 25, No. 2, (2009), pp. 250-256.
- [13] Abhang LB, Hameedullah M. Modeling and analysis for surface roughness in machining en-31 steel using response surface methodology, International Journal of Applied Research in Mechanical Engineering, Vol. 1, No. 1, (2011), pp. 33-38.
- [14] Khorasani AM, Yazdi MRS, Safizadeh MS. Tool life prediction in face milling machining of 7075 al by using artificial neural networks (ANN) and taguchi design of experiment (DOE), International Journal of Engineering and Technology, Vol. 3, No. 1, (2011), pp. 30-35.
- [15] Metin Kok. Modeling and assessment of some factors that influence surface roughness for the machining of particle reinforced metal matrix composites, Arabian Journal for Science and Engineering, Vol. 36, No. 7, (2011), pp. 1347-1365.
- [16] Ezugwu EO, Okeke CI. Performance of PVD coated carbide inserts when machining a nimonic C-263 alloy at high speed conditions, Tribology Transaction, Vol. 43, No. 2, (2000), pp. 332-336.
- [17] Liao YS, Huang JT, Su HC. A study on the machining-parameters optimization of wire electrical discharge machining, Journal of Materials Processing Technology, Vol. 71, No. 3, (1997), pp. 487-493.
- [18] Lok YK, Lee TC. Processing of advanced ceramics using the wire-cut EDM process, Journal of Materials Processing Technology, Vol. 63, Nos. 1-3, (1997), pp. 839-843.
- [19] Park SH. Robust design and analysis for quality engineering, Chapman & Hall, London, (1996).

- [20] Phadke MS. Quality engineering using design of experiment, quality control, Robust Design and The Taguchi Method, Wadsworth & Books, California, (1988).
- [21] Liu CH, Andrian C, Chen CA, Wang YT. Grinding force control in automatic surface finish system, Journal of Materials Processing Technology, Vol. 170, (2005), pp. 367-373.
- [22] Antony J, Perry D, Wang C, Kumar M. An application of taguchi method of experimental design for new product design and development process, Assembly Automation, Vol. 26, No. 10, (2006), pp. 18-24.
- [23] Zhang JZ, Chen JC, Kirby ED Surface roughness optimization in an end-milling operation using the taguchi design method, Journal of Material Processing Technology, Vol. 184, (2007), pp. 233-239.
- [24] Antony J, Kaye M. Experimental quality – a strategic approach to achieve and improve quality, Kluwer Academic Publishers, Dordrecht, December, (1999).
- [25] Ross PJ. Taguchi Techniques for Quality Engineering, McGraw Hill Publishers, New York, (1988).
- [26] Kaladhari M, Subbaiah KV. Application of taguchi approach and utility concept in solving the multi-objective problem when turning aisi 202 austenitic stainless steel, Journal of Engineering Science and Technology Review, Vol. 4, No. 1, (2011), pp. 55-61.
- [27] Nian CY, Yang WH, Tarang YS. Optimization of turning operations with multiple performance characteristics, Journal of Material Process Technology, Vol. 95, (1999), pp. 90-96.
- [28] Bandit Suksawat. Development of in-process surface roughness evaluation system for cast nylon 6 turning operation, Procedia Engineering, Vol. 15, (2011), pp. 4841-4846.
- [29] Bandit Suksawat. Experimental investigations of cutting conditions influence on main cutting force and surface roughness based on chip form types in cast nylon turning, Applied Mechanics and Materials, Vol. 3563, (2011), pp. 110-116.
- [30] Kabayahi A. Machining of Plastics, McGraw-Hill, New York, (1967).
- [31] Gaitonde VN, Karnik SR, Paulo Davim J. Multi-performance optimization in turning of free-machining steel using taguchi method and utility concept, Journal of Materials Engineering and Performance, Vol. 18, No. 3, (2009), pp. 231-236.
- [32] Fisher RA. Statistical methods for research worker, London: Oliver & Boyd, (1925).